



## SUPPLEMENTARY REGULATIONS

Winter auto show, Rogla 2004  
16.- 18. January 2004

<b>I. PROGRAMME</b> .....	3
<b>II. ORGANISATION</b> .....	3
2.1. Definition .....	3
2.1.1. Name of the event .....	3
2.1.2. Organiser .....	3
2.2. Organising committee.....	3
2.3. Address of the permanent secretariat .....	3
2.4. Officials of the event.....	3
2.4.1. Officials:.....	3
2.4.2. Stewards of the meeting.....	4
<b>III. DESCRIPTION OF EVENT</b> .....	4
3.1. Route .....	4
3.1.1. Length .....	4
3.1.2. Surface.....	4
3.2. Competition .....	4
3.2.1. Qualifying .....	4
3.2.2. Falling out 1 .....	4
3.2.3. Semi final .....	4
3.2.4. Final.....	4
3.2.5. Super-Final .....	4
<b>IV. ELIGIBLE CARS</b> .....	4
4.1. Permitted cars .....	4
4.2. Classes .....	4
4.3. Tyres.....	4
4.3.1. Dimensions of the studs.....	4
4.3.2. Quantity of studs .....	4
<b>V. ENTRIES, ENTRY FORM</b> .....	5
5.1. Entries .....	5
5.2. Entry fee.....	5
<b>VI. ADVERTISING</b> .....	5
6.1. Permitted advertising.....	5
6.2. Organiser's advertising.....	5
<b>VII. GENERAL OBLIGATIONS</b> .....	5
7.1. Control of driver's equipment.....	5
7.2 Numbers.....	5
7.3. Service .....	5
7.4. Protection tarpaulin .....	5
<b>VIII. ADMINISTRATIVE CHECK , SCRUTINEERING</b> .....	5
8.1. Administrative check .....	5
8.2. Documents needed.....	5
8.3. Scrutineering .....	6
<b>IX. INSPECTION OF THE TRACK</b> .....	6
9.1. Date.....	6
<b>X. SIGNALISATION</b> .....	6
10.1. Following signalisation flags will be used.....	6
10.2. Consider of signalisation.....	6
<b>XI. PROTESTS - APPEALS</b> .....	6
11.1. Time for put the protest.....	6
11.2. Sum of the protest .....	6
11.3. Decision of the stewards of meeting.....	6
<b>XII. PRIZES - CUPS</b> .....	6
12.1. Cups.....	6
<b>XIII. PRIZE GIVING CEREMONY</b> .....	6
13.1. Participating on price giving ceremonial .....	6
13.2. Loosing rights for cups .....	6
<b>XIV. GENERAL REGULATIONS</b> .....	6
14.1. Changes.....	6

## **I. PROGRAMME**

10. December 2003	Opening date for entries. Regulation are published.	
12. January 2004	Closing date for entries (24 <sup>h</sup> )	
16. January 2004	from 16:00 to 18:00	Administrative check, Scrutineering
	from 16:00 to 18:00	Reconnaissance (each competitor once maximum)
17. January 2004	from 08:00 to 10:00	Administrative check, Scrutineering
	from 09:00 to 10:30	Reconnaissance (each competitor once maximum)
	from 11:00 to 15:00	Qualifying
	from 11:00	SS A1 (Koča na Pesku – Slovenska Bistrica)
	from 12:00	SS B1 (Slovenska Bistrica – Koča na Pesku)
	from 13:00	SS A2 (Koča na Pesku – Slovenska Bistrica)
	from 14:00	SS B2 (Slovenska Bistrica – Koča na Pesku)
17. January 2004	from 08:00 to 13:00	Duels
	from 08:00	Class 1 – fastest 25 – SS A
	from 08:40	Class 1 – fastest 25 – SS B
	from 09:20	Class 2 – fastest 25 – SS A
	from 10:00	Class 2 – fastest 25 – SS B
	from 11:00	Class 1 – fastest 12 – SS A
	from 11:25	Class 1 – fastest 12 – SS B
	from 12:00	Class 2 – fastest 12 – SS A
	from 12:25	Class 2 – fastest 12 – SS B
	from 14:00 to 16:15	Final
	from 14:00	Class 1 – fastest 6 – SS A
	from 14:20	Class 1 – fastest 6 – SS B
	from 15:00	Class 2 – fastest 6 – SS A
	from 15:20	Class 2 – fastest 6 – SS B
	from 15:50	Super-final – SS A
	from 16:00	Super-final – SS B
	at 16:15	Prize giving ceremonial

Exact programme will be published after closing date for entries.

## **II. ORGANISATION**

Winter autoshow 2004 will run in compliance with the International Sporting Code (and its appendices), the General Prescriptions applicable to FIA championship rallies and these supplementary regulations.

### **2.1. Definition**

#### **2.1.1. Name of the event**

3. winter auto show, Rogla 2004

#### **2.1.2. Organiser**

Sidol d.o.o.

### **2.2. Organising committee**

Chairman:		Primož Lemež
Members:	Clerk of the course	
	Press relations	Erik Logar
	Security	Mladen Klavora
	Doctor	Dr. Andrej Stare

### **2.3. Address of the permanent secretariat**

SIDOL d.o.o.

Jakopičeva 2

1000 Ljubljana

Slovenija

Telefon : (+386 1 5441341)

Fax: (+386 1 5441341)

GSM: +386 41 680993

E – mail: [primoz.lemez@siol.net](mailto:primoz.lemez@siol.net) WEB: [www.mpiracing.com/winter-autoshow](http://www.mpiracing.com/winter-autoshow)

### **2.4. Officials of the event**

#### **2.4.1. Officials:**

Clerk of the course

Assistant Clerks of the Course  
Chief Safety Officer  
Time keeping

#### 2.4.2. Stewards of the meeting

Chairman  
Member  
Member

### III. DESCRIPTION OF EVENT

#### 3.1. Route

##### 3.1.1. Length

Length of the course is approx. 2.5 km.

##### 3.1.2. Surface

Snow and ice.

#### 3.2. Competition

##### 3.2.1. Qualifying

Race will be on one road and it will be driven in both directions (direction A and direction B). Competitor drive 4 races for qualifying (two races in each direction). The worst time of each direction will be deleted.

##### 3.2.2. Falling out 1

In falling out 1 races the fastest 25 drivers of each class will compete. The fastest 12 drivers of each class goes to 1/2 final. Falling out 1 race will be driven in both directions only once and sum of both races is the result which will count.

##### 3.2.3. Semi final

In Semi final the fastest 12 drivers from Falling out 1 races of each class will compete. Semi final race will be driven in both directions only once and sum of both races is the result which will count. The fastest 6 drivers of each class goes to the final.

##### 3.2.4. Final

In final the fastest 6 drivers from semi final of each class will compete. Final race will be driven in both directions only once and sum of both races is the result which will count. The fastest driver of each class goes to the super final.

##### 3.2.5. Super-Final

In super-final the fastest drivers from each class will compete. Final race will be driven in both directions only once and sum of both races is the result which will count. Winner of super final is the official winner of 3. winter autoshow, Rogla 2004.

### IV. ELIGIBLE CARS

#### 4.1. Permitted cars

All vehicles which comply Appendix J of international sporting regulations are allowed.

#### 4.2. Classes

- class 1: 2 wheel drive vehicles
- class 2: 4 wheel drive vehicles

The organiser can combine classes if at least 4 cars won't be entered.

#### 4.3. Tyres

##### 4.3.1. Dimensions of the studs

Maximum dimensions of the studs are defined as it is shown in Picture 1.

##### 4.3.2. Quantity of studs

The number of studs must not exceed 20 per any decimetre of the wheel circumference.

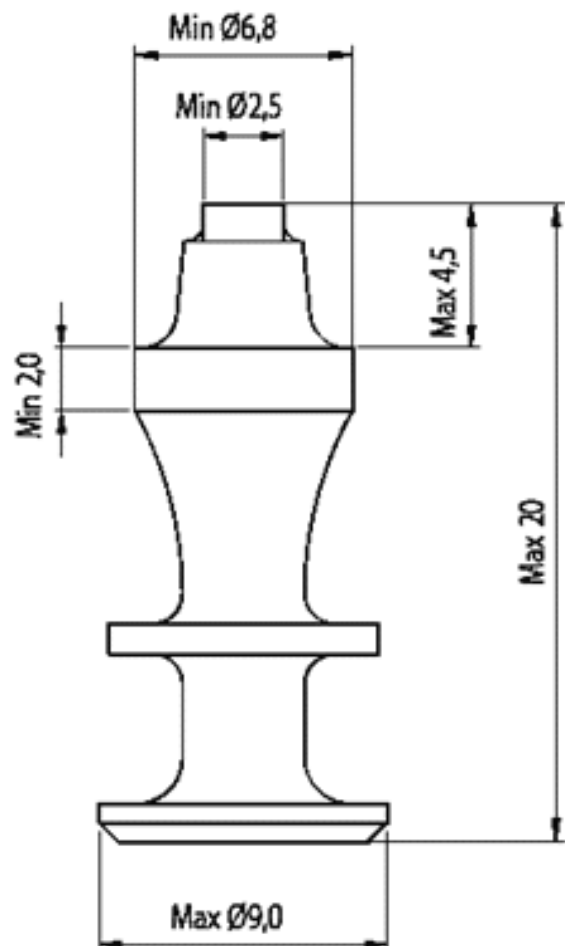

Picture 1

## **V. ENTRIES, ENTRY FORM**

### **5.1. Entries**

Correct filled entry forms must be sent to:

MPI RACING IDRIJA  
Za Avto Show  
Grilčeva 4  
5280 Idrija  
Slovenija  
fax (+386 5 377 38 60)

If this application is sent by fax, the original entry form must reach the organiser no later than one day after the close of entries.

With signature on registration form, every driver accepts full responsibility for damage, caused by driver himself, member or companion of his team. By signing the registration form driver accepts full responsibility for attending the competition and will not have any demands or claims to organiser.

Organiser is not responsible for any damage on vehicles of drivers teams.

### **5.2. Entry fee**

There is no entry fee.

## **VI. ADVERTISING**

### **6.1. Permitted advertising**

Advertising is allowed by regulations of Slovenian legislation and in accordance with FIA regulations and general rules of FIA championships.

### **6.2. Organiser's advertising**

Space for sponsors advertises on vehicles must be provided. They are obligatory and driver can't refuse to put them on their vehicles.

## **VII. GENERAL OBLIGATIONS**

### **7.1. Control of driver's equipment**

Helmets and other equipment will be controlled at technical examination before beginning of the competition.

### **7.2 Numbers**

Racing numbers, assigned by organiser must be placed on both front doors of the vehicle and must remain there during the competition

### **7.3. Service**

Boxes are placed near racing track. Every box has its place before and after competition. Vehicles are arranged in boxes by boxes director. Driver must place his vehicle in box immediately after technical examination. Drivers go to start from boxes. In box area driver can bring only his racing car and one accompanying vehicle, which must receive permission at verification.

### **7.4. Protection tarpaulin**

At servicing or repairing the car, protection tarpaulin, size 5x2 m, impermeable to oil and gasoline, must be put under the vehicle. Service area must be cleaned after service.

## **VIII. ADMINISTRATIVE CHECK , SCRUTINEERING**

### **8.1. Administrative check**

Administrative check will take place at Koča na Pesku on Friday 16 January from 16 to 18 and on Saturday 17 January from 7 and 9 AM..

### **8.2. Documents needed**

At verification confirmation about paid mishap insurance (2 million SIT in case of death and 4 million SIT in case of disability) must be shown. Insurance for two days of competition will be possible to make at verification..

### **8.3. Scrutineering**

Scrutineering will take place in the same spot as administrative check, immediately after administrative check.

## ***IX. INSPECTION OF THE TRACK***

### **9.1. Date**

Inspection of the track will be possible on Friday 16 January from 16 to 18:00 and on Saturday 17.01.2004 from 7 and 9:00 AM. Each competitor could only drive twice through the stage in each direction following the rules of clerk of the course.

## ***X. SIGNALISATION***

### **10.1. Following signalisation flags will be used**

- Yellow flag - danger
- Red flag - interruption of the race

### **10.2. Consider of signalisation**

Drivers are obliged to consider signalisation of functionaries. Competitor, who will not follow rules or signalisation, will be disqualified.

## ***XI. PROTESTS - APPEALS***

### **11.1. Time for put the protest**

Driver must put his protest in writing in 10 minutes after the race and give it to director of the race

### **11.2. Sum of the protest**

Sum for the protest is set at 30.000,00 SIT.

### **11.3. Decision of the stewards of meeting**

Stewards of the meeting will discuss about the protest. Their decision is terminal.

## ***XII. PRIZES - CUPS***

### **12.1. Cups**

Cups go to 1-st, 2-nd and 3-rd driver in individual class.

## ***XIII. PRIZE GIVING CEREMONY***

### **13.1. Participating on price giving ceremonial**

All classified teams must participate at award-giving ceremony and winners must participate in any other ceremonies. Winning vehicle in general classification and every winning vehicle of individual class must attend award-giving ceremony.

### **13.2. Loosing rights for cups**

If drivers don't attend the ceremony, or fail to bring their vehicles, they can't get the cup.

## ***XIV. GENERAL REGULATIONS***

### **14.1. Changes**

Organiser has a right to interpret these regulations. Organiser can change regulations or put additional instructions into force. Regulations have to be presented to registered competitors; before competition in writing, and during competition on official notice board.

Idrija, 04.12.2003

Clerk of the course  
Miran Kacin